

Appendix F: Bus Stop Diagrams



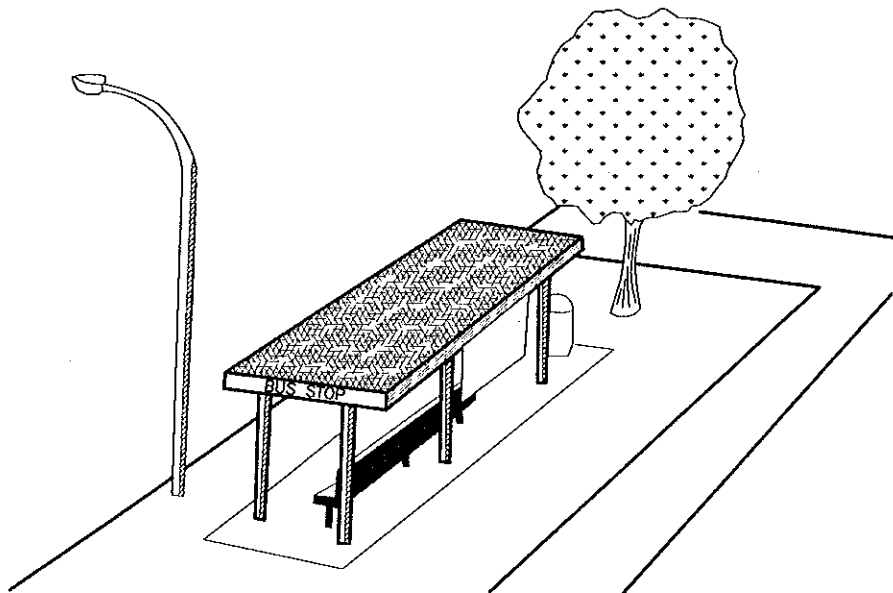

FIGURE 21
 EXAMPLE OF COORDINATING BUS STOP LOCATION WITH AN EXISTING STREET LIGHT

SOURCE: TCRP REPORT 19, *GUIDELINES FOR THE LOCATION AND DESIGN OF BUS STOPS*

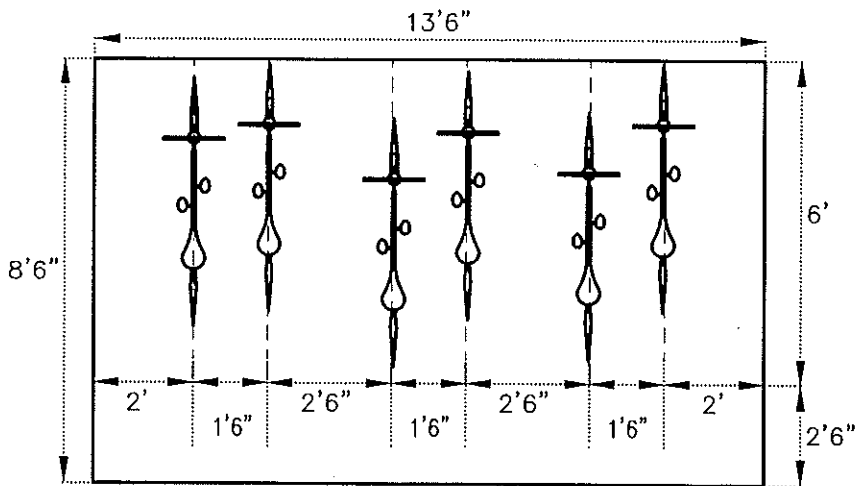
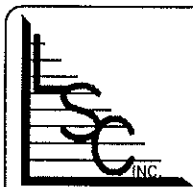

FIGURE 22
 RECOMMENDED SPACE FOR PARKING SIX BICYCLES



LSC NO.:
 987190-NT2122

FIGURE NO.:
 21 & 22

**BUS STOP COORDINATION WITH STREET LIGHTS &
 RECOMMENDED SPACE FOR BICYCLE PARKING**

NAPA TRANSIT IMPROVEMENT STANDARDS STUDY

WITHOUT SHELTER/WITH OR WITHOUT BENCH

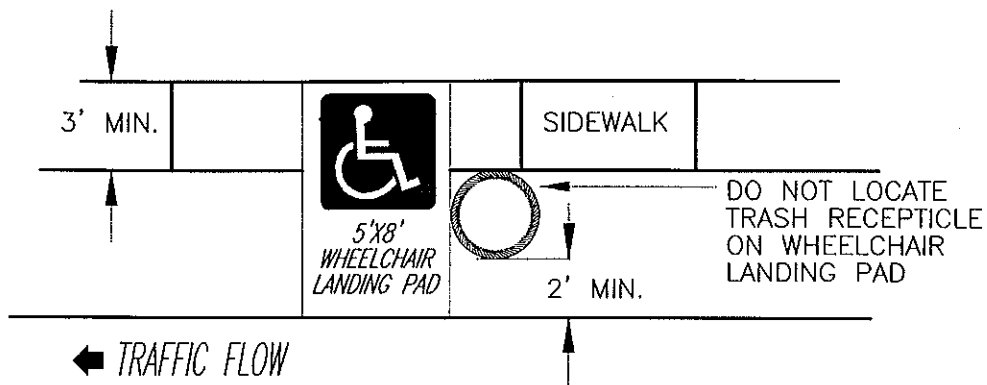

WITH SHELTER

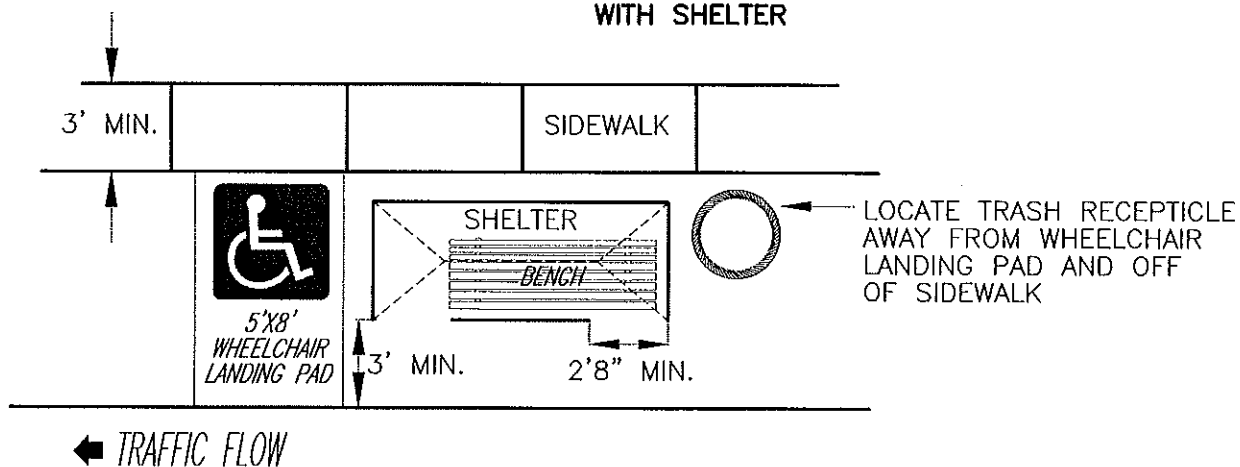
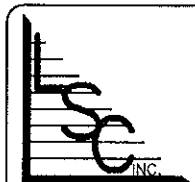

FIGURE 20
RECOMMENDED TRASH RECEPTACLE PLACEMENT

SOURCE: TCRP REPORT 19, *GUIDELINES FOR THE LOCATION AND DESIGN OF BUS STOPS*



LSC NO.:
987190-NTTRASH

FIGURE NO.:
20

RECOMMENDED TRASH
RECEPTACLE PLACEMENT

NAPA TRANSIT IMPROVEMENT STANDARDS STUDY